



U.S. Department  
of Transportation

**Federal Highway  
Administration**

December 28, 1999

400 Seventh St., S.W.  
Washington, D.C. 20590

Refer to: HMHS

Mr. Dave Gertz  
Director of Engineering  
TrafFix Devices, Inc.  
220 Calle Pinteroesco  
San Clemente, California 92672

Dear Mr. Gertz:

Thank you for your letter of August 19 requesting the Federal Highway Administration (FHWA) find a number of your company's work zone traffic control devices as crashworthy and acceptable for use on the National Highway System (NHS) under the provisions of the National Cooperative Highway Research Program Report 350 "Recommended Procedures for the Safety Performance Evaluation of Highway Features." Accompanying your letter was a copy of the crash test report by Karco Engineering and video documentation of the crash tests. In response to our request you sent additional information on November 17, 1999.

The FHWA guidance on crash testing of work zone traffic control devices is contained in two memoranda. The first dated July 25, 1997, titled "Information: Identifying Acceptable Highway Safety Features," established four categories of work zone devices: Category I devices were those lightweight devices which could be self-certified by the vendor, Category II devices were other lightweight devices which needed individual crash testing, Category III devices were barriers and other fixed or massive devices also needing crash testing, and Category IV devices were trailer mounted lighted signs, arrow panels, etc. The second guidance memorandum was issued on August 28, 1998, and is titled "INFORMATION: Crash Tested Work Zone Traffic Control Devices." This recent memorandum lists devices that are acceptable under Categories I, II, and III.

Full-scale automobile testing was conducted on your company's cones, tubes, barricades, drums, and portable sign supports. The unlighted cones and tubes are Category I devices and do not need an acceptance letter from the FHWA, but they will be included in the lists below for continuity. Two examples of each Category II device were tested in tandem, one head-on and the next at 90 degrees, as called for in our guidance memoranda. The items in the following table were included in this testing program:

Item Name	Ballast, Lights, Flags	Test #	WZ Category Designation
28-inch Grabber Tube	5.5 kg rubber base	1	Category 1
28-inch Grabber Cone	4.5 kg rubber base	1	Category 1
42-inch Grabber Tube	5.5 kg rubber base	1	Category 1
42-inch Grabber Cone	7.3 kg rubber base	1	Category 1
Model 18000 HDPE Drum with Tire Ring	Empco-Lite Model #100 with 11 kg Tire Ring	2	Category 2
42- inch Grabber Cone	Empco-Lite Model #100 with 13.6 kg rubber base	3	Category 2
Vertical Panel Barricade	Empco-Lite Model #100 19.5 kg rubber base	4	Category 2
Economy Plastic Folding Barricade, sand-filled panels	Empco-Lite Model #100 8.2 kg ballasted top panels	5	Category 2
42-inch Traffix Cone	Empco-Lite Model #100 6.8-kg sand-filled base	6	Category 2
Traffix A-Cade, 8-foot Traffix rail	Empco-Lite Model #100 2.7 kg sand Ballast	7	Category 2
Big Buster Dual Spring Folding Leg Sign Stand	1.5 m mounting height 1220 mm rollup signs, 3 flags	8	Category 2
Little Buster Dual Spring Folding Sign Stand	1270 mm mounting height 1220 mm rollup signs, 3 flags	10	Category 2
Econo Buster Sign Stand	1270 mm mounting height 1220 mm rollup signs, 3 flags	11	Category 2

Drawings/specification sheets for the devices tested are enclosed. All lights were securely attached to the test articles with a "light bolt heavy duty protector" also shown in the enclosure.

All tests were conducted with an 844-kg or an 845-kg automobile with a live driver. The tests and their results are summarized in the following table.

Test No.	Impact Speed (km/hr)	Impact Speed (km/hr)	Velocity Change (m/s)*	Description of Damage to Windshield	Results	Device
	Head-on	90-deg.				
1	105.9	102.8	0.43	No contact	Pass	Tube, Cone
2	101.8	92.9	1.24	No contact	Pass	Drum
3	102.5	100.2	0.32	No contact	Pass	Cone
4	104.3	100.7	0.50	No contact	Pass	Vert. Panel
5	103.9	85.4	2.57	Contact, no damage	Pass	Plastic barricade
6	103.0	100.4	0.44	No contact	Pass	Cone
7	104.1	98.1	0.84	No contact	Pass	Barricade
8	103.5	92.1	1.59	Minor cracking	Pass	Sign stand
10	102.8	97.8	0.69	Shattered, No Intrusion	Pass	Sign stand
11	100.5	82.4	2.52	Shattered, no intrusion	Pass	Sign stand

\* Velocity change is the average vehicle velocity change per impact across both devices.

The results of tests 1-8, 10, and 11 met the FHWA requirements and, therefore, the following devices are acceptable for use on the NHS under the range of conditions tested, when proposed by a State:

- 28-inch Grabber Tube, ballasted
- 28-inch Grabber Cone, ballasted
- 42-inch Grabber Tube, ballasted
- 42-inch Grabber Cone, ballasted
- Model 18000 HDPE Drum with light and Tire Ring
- 42-inch Grabber Cone, ballasted, with light
- Vertical Panel Barricade, ballasted, with light
- Economy Plastic Folding Barricade, sand-tilled panels, with light
- 42-inch Traffix Cone, ballasted, with light
- Traffix A-Cade, 8-foot rail, ballasted, with light
- Big Buster Dual Spring Folding Leg Sign Stand, with rollup sign at 1.5 m
- Little Buster Dual Spring Folding Sign Stand, with rollup sign at 1.27 m
- Econo Buster Sign Stand, with rollup sign at 1.27 m

Our acceptance is limited to the crashworthiness characteristics of the devices and does not cover their structural features, nor conformity with the Manual on Uniform Traffic Control Devices. Presumably, you will supply potential users with sufficient information on design and installation requirements to ensure proper performance. We anticipate that the States will require certification from Traffix Devices, Inc., that the hardware furnished has essentially the same chemistry, mechanical properties, and geometry as that submitted for acceptance. To prevent misunderstanding by others, this letter of acceptance, designated as number WZ-24, shall not be reproduced except in full.

If any of your company's work zone traffic control devices are patented products they are considered "proprietary." The use of proprietary work zone traffic control devices in Federal-aid projects is generally of a temporary nature. They are selected by the contractor for use as needed and removed upon completion of the project. Under such conditions they can be presumed to meet requirement "a" given below for the use of proprietary products on Federal-aid projects. On the other hand, if proprietary devices are specified for use on Federal-aid projects, except exempt, non-NHS projects, they: (a) must be supplied through competitive bidding with equally suitable unpatented items; (b) the highway agency must certify that they are essential for synchronization with existing highway facilities or that no equally suitable alternative exists or; (c) they must be used for research or for a distinctive type of construction on relatively short sections of road for experimental purposes. Our regulations concerning proprietary products are contained in Title 23, Code of Federal Regulations, Section 635.411, a copy of which is enclosed.

Sincerely yours,



Dwight A. Horne

Director, Office of Highway Safety Infrastructure

Enclosure

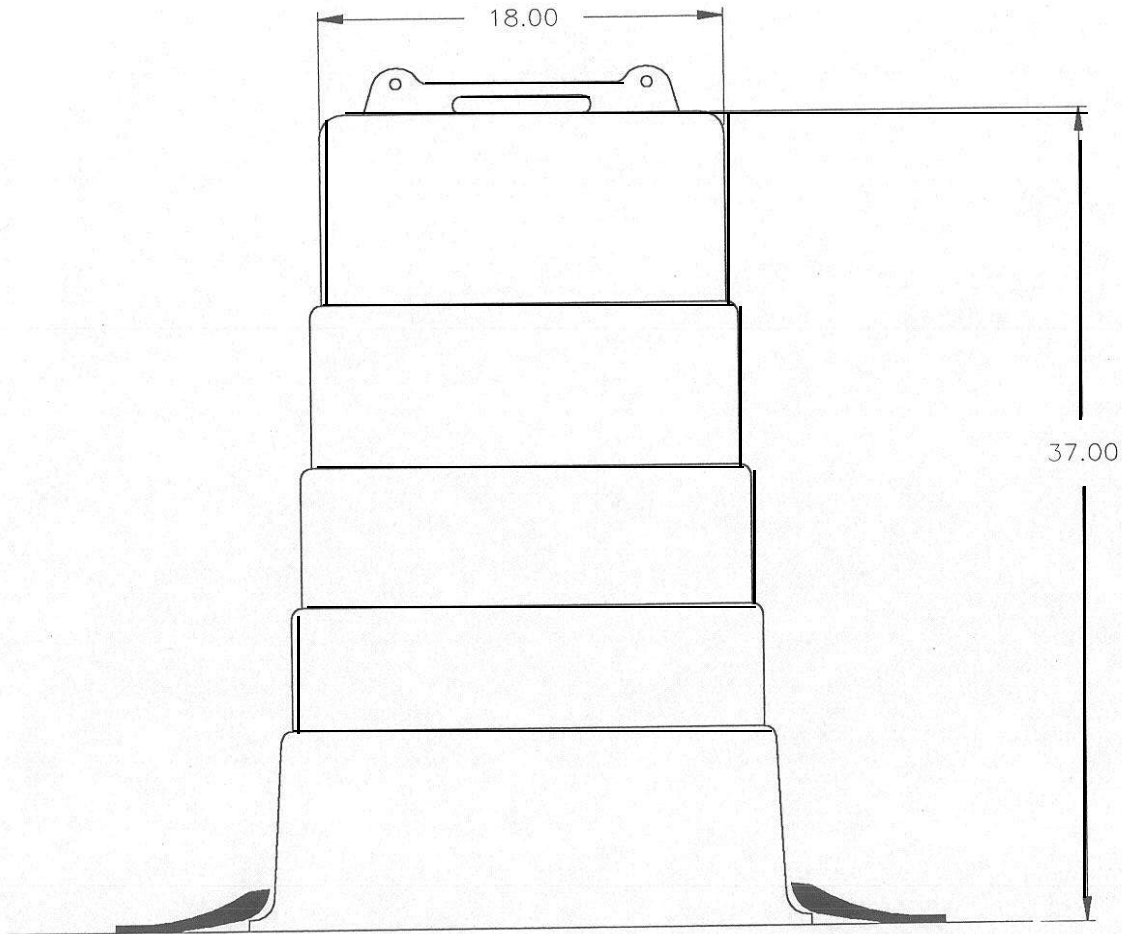

Revision	Revision Description	Approved	Date
-	New part		11/12/92

TOLERANCES UNLESS OTHERWISE SPECIFIED  
 DECIMALS ANGLES  
 .XX = 0.03 1/2°  
 .XXX = 0.005  
 FRACTIONS  
 +1/32 -0

**TrafFix Devices, Inc.**

Title: #18000 HPDE DRUM W/TIRE RING

Directory: CAD File No. 10016 Drawing No. 10016 Rev. -

Scale: Size: C Sheet 1 of 1

10016

## Two Piece Vertical Panel

### 1. Dimensional Requirements:

- a. Vertical Panel height 40"
- b. Vertical panel Width 14"
- c. Vertical Panel thickness 2"
- d. Specific Panel Dimensions:  
[bid per the checked panel (s)]

12" x 24" 1 side  
12" x 24" 2 sides  
**12" x 30" 1 side**  
**12" x 30" 2 sides**

(Panels have rounded corners)

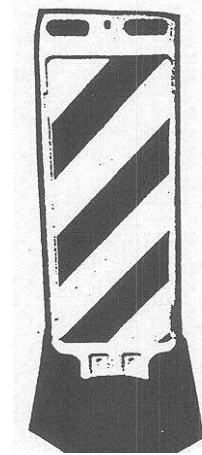

Vertical Panel

### 2. Sheeting Requirements:

(Bid per checked sheeting)

Engineer Grade (orange & white)  
High intensity (orange & white)

### 3. Base Requirements:

(Bid checked base)

42lb. base  
30lb. base

### 4. Additional Information:

Vertical panel is to be of 2-piece breakaway design consisting of either a 42 lb. or 30 lb. recycled rubber base and a 5 lb. high density polyethylene panel.. The VP panel has an 8" wide bottom that is inserted into a matching socket in the base. Socket has two vertical ribs on each side 1 1/2" wide which prevent panel from rocking side to side. Base socket includes a laminated recess area that engages a locking button on the panel to secure the panel in the base. Panel pulls free from base on impact by an automobile. Reflective sheeting is applied to H.D.P.E. backing which is then welded to the panel. The VP handle shall be designed to secure a light on the top by bolting a light on using the center hole in the handle. Color: the panel is to be white. The base is to be black in color.



# TrafFix Plastic Folding Barricade

## The Latest Innovation In Plastic Barricades



*Type I Barricade with 8'x24" top panel and 4'x24" bottom panel.*



*Type I Barricade with 12'x24" top panel and 4'x24" bottom panel.*



*Type I Barricade with 8'x24" top panel and 8'x24" San-Fil bottom panel.*



*Type II Barricade with 8'x24" top panel and bottom panel.*



*Vertical Panel Barricade with 12'x24" panel.*



*Type I Barricade with 12'x24" top panel and 8'x24" San-Fil bottom panel.*

TrafFix Devices offers you a wide range of options to fulfill all of your barricade requirements. Because the Plastic Folding Barricade is assembled with individual components, you can select any combination of top and bottom panels as illustrated in this brochure. You can also specify engineer grade or high intensity reflective sheeting.

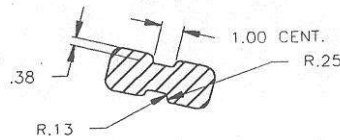
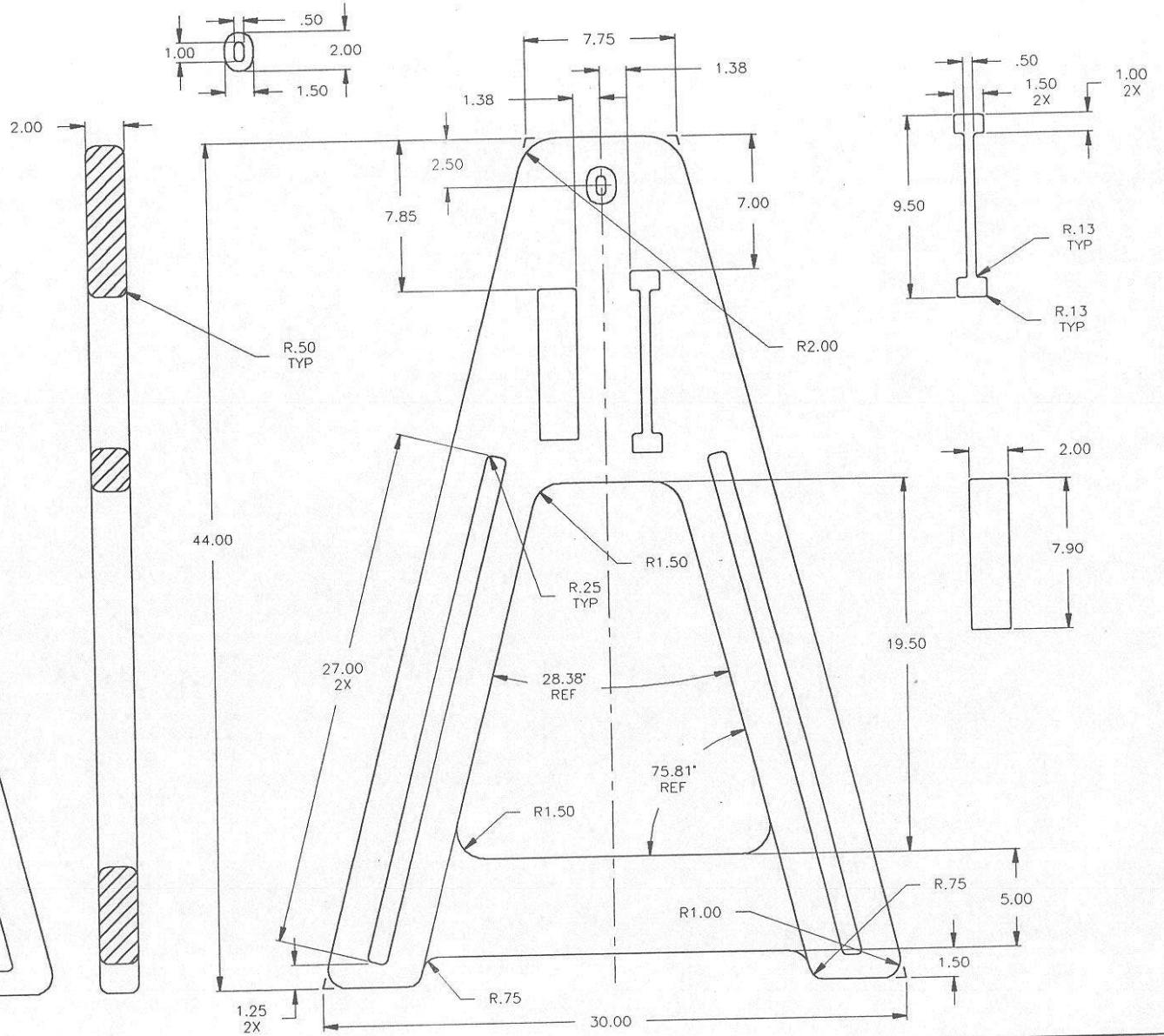
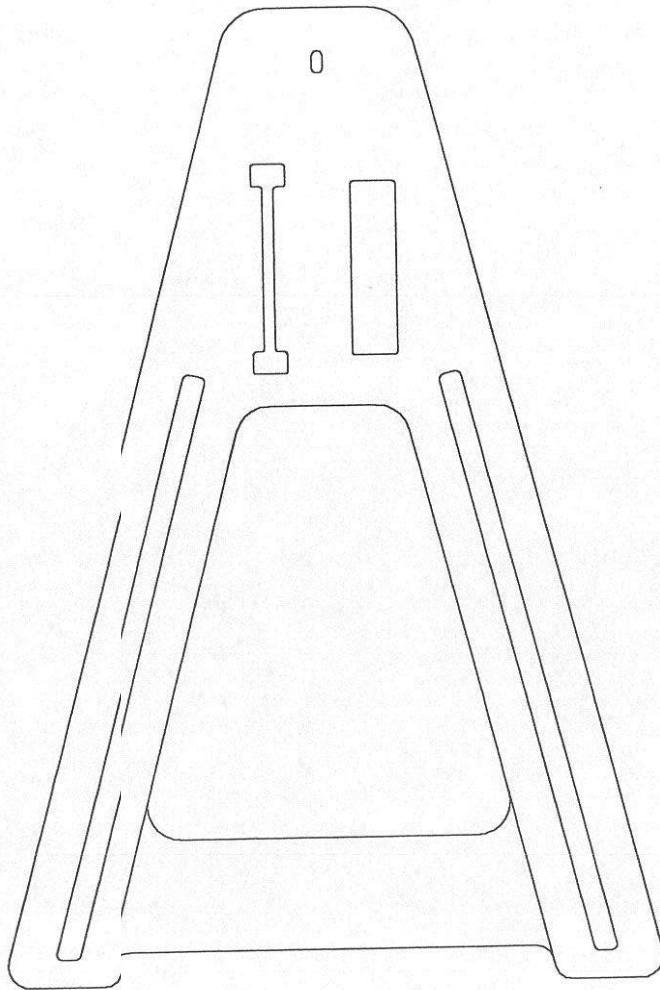

NOTES:

TOLERANCES UNLESS OTHERWISE SPECIFIED		Title	
DECIMALS	ANGLES	A-FRAME	
XX = 0.05	1/2°	Directory	CAD File No.
XXX = 0.005		10032	Drawing No. 10032
FRACTIONS		5/19/99	10032
+1/32 -0		Approved	Date
Revision	Revision Description	Scale:	Size: C Sheet 1 of 1

TrafFix Devices, Inc.



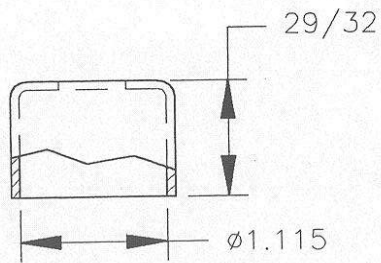
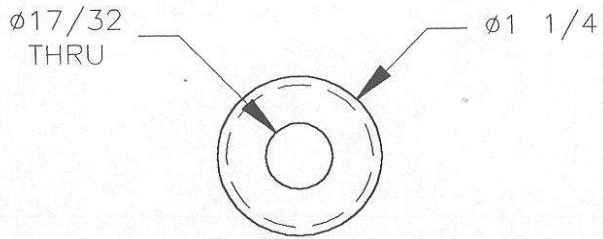

LIGHT BOLT  
HD PROTECTOR

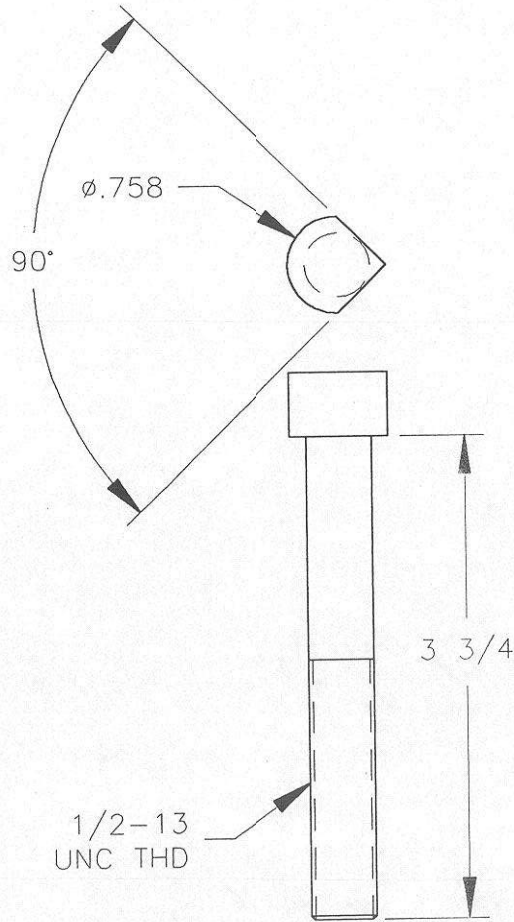

SPECIAL BOLT  
STEEL

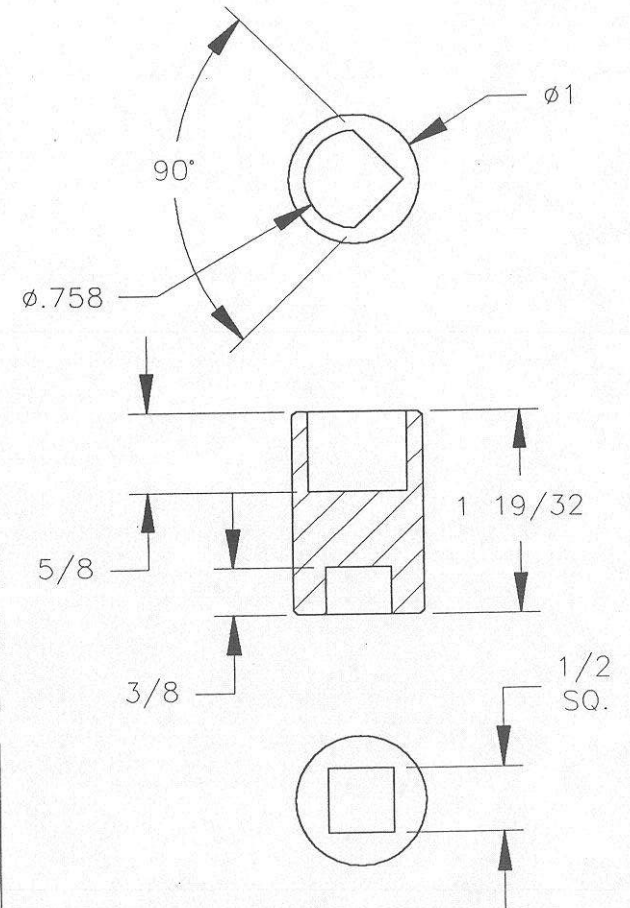

SPECIAL SOCKET  
FOR  $1/2$ " DRIVE  
STEEL

NOTES:

Revision	Revision Description	Approved	Date
-	NEW PART		11/13/99

TOLERANCES UNLESS  
OTHERWISE SPECIFIED

DECIMALS ANGLES  
XX =  $\pm .03$   $\pm 1/2$   
XXX =  $\pm .005$

FRACTIONS  
 $+1/32 -0$

<b>TraFFix Devices, Inc.</b>			
Title DETAILS, LIGHT HD BOLT PROTECTOR			
Directory	CAD File No. 10031	Drawing No. 10031	Rev -
Scale: 1/2		Size: B Sheet 1 of 1	

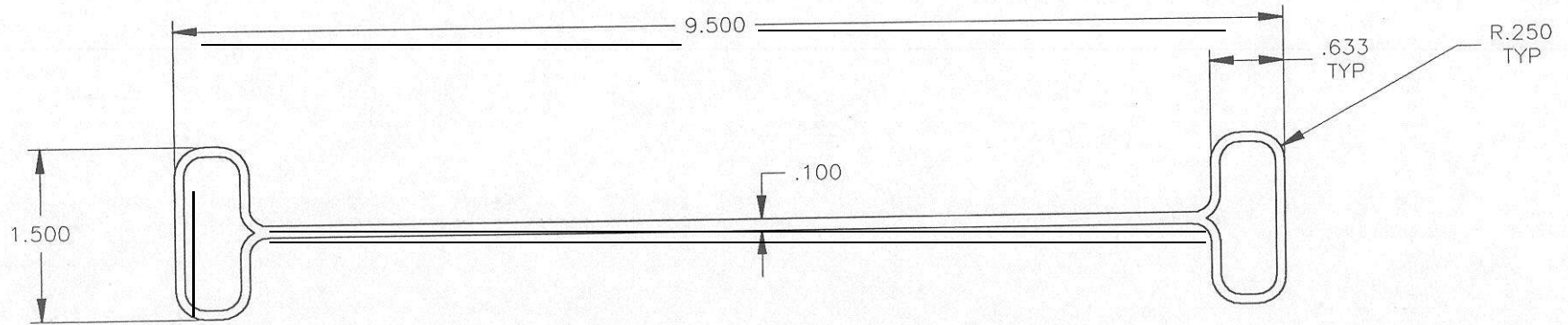

1. MATERIAL: HDPE

NOTES:

Revision	Revision Description	Approved	Date
NEW PART			11/12/99

TOLERANCES UNLESS OTHERWISE SPECIFIED

DECIMALS ANGLES

.XX = ±.03 ±1/2°

.XXX = ±.005

FRACTIONS

+1/32 -0

<b>TrafFix Devices, Inc.</b>			
Title			
RAIL, HDPE			
Directory	CAD File No.	Drawing No.	Rev
	RAIL	10030	-
Scale: FULL		Size: B	Sheet 1 of 1

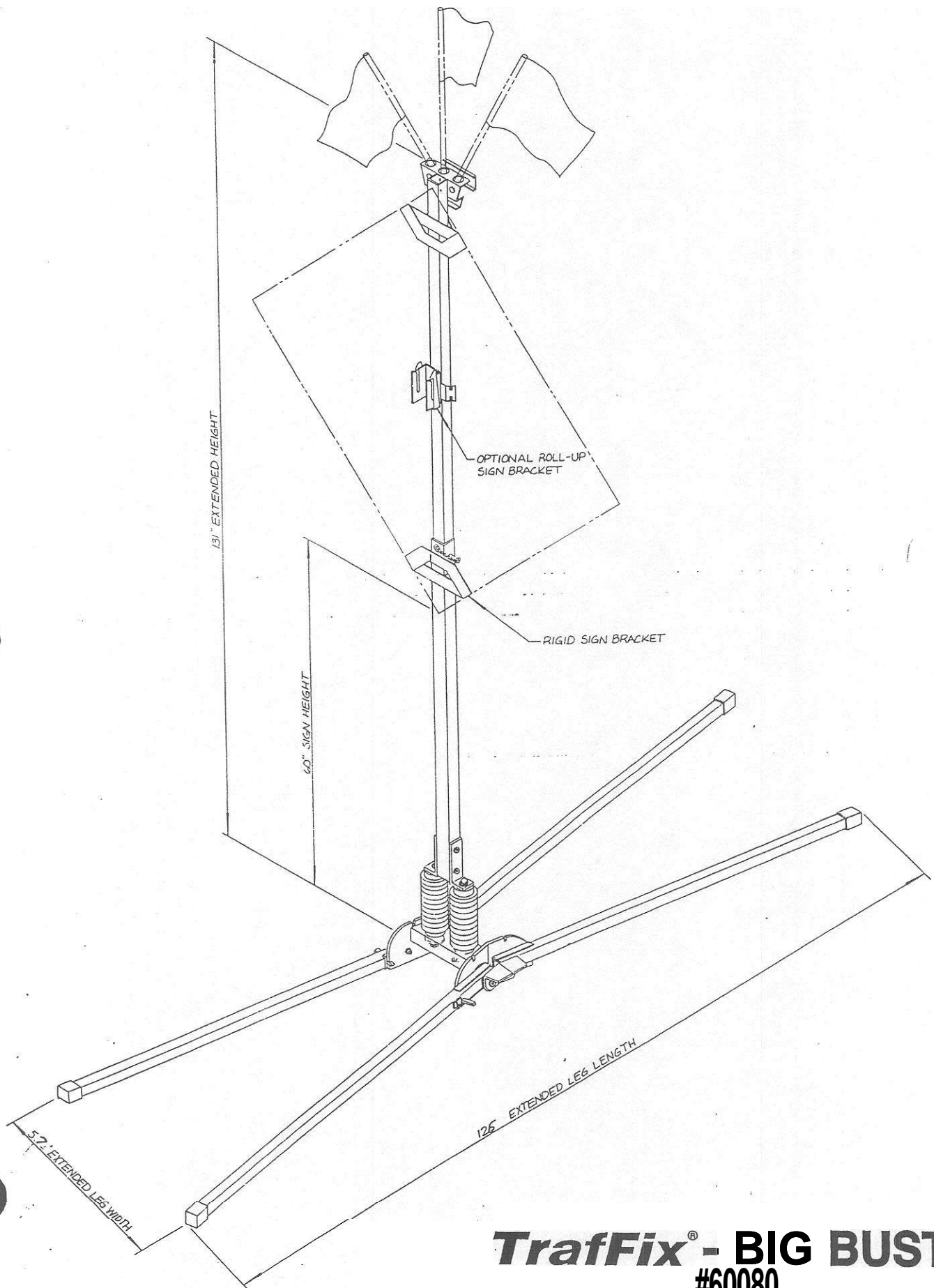

**TrafFix® - BIG BUSTER™**  
**#60080**

# TraFFix® - BIG BUSTER™

## #60000

ITEM #	PART #	ITEM DESCRIPTION	QTY. ASSEM.
1	60001	Base Plate	1
2	24302	Hex. Lock nut	4
3	24303	Space Washer	8
4	24304	Hex. Bolt	4
5	60005	Tie Bracket	2
6	60006	Channel Bracket	4
7	60007	Step lever	4
8	24308	Extension Spring	4
9	24309	Cover Plate	4
10	24310	Round Head Screw	8
11	60011	Leg (Excluding 60007,24308, 24309,& 60010)	4
12	60012	Insert Plug(Spring holder)	4
13	60013	Spring	2
14	60014	Spring Bracket	2
15	60015	Hex. Bolt	4
16	24316	Lock Washer	4
17	24317	Hex. Bolt	2
18	24318	Hex. Lock Nut	2
19	60019	Rigid Sign Bracket	2
20	60020	Outer Mast	1
21	60021	3/16" X 5/16" Rivet	1
22	60022	Faspin C5-16-R, with Chain	1
23	60023	Inner Mast (Excluding 24324, 60025, & 60026)	1
24	60024	Flag Holder Assembly	1
25	60025	#10-24 x 1/2" Phil. Hd. Screw	2
26	60026	#10-24 Lock Nut	2
27	24327	Cap Adhesive (Tube)	1
28	60028	Black Cap	4
29	24329	1/2" I. D. Hvy. Washer	2
31	60031	Decal & Label	1
35	60035	Spring Loaded Roll-Up Sign Bracket(Optional)	1

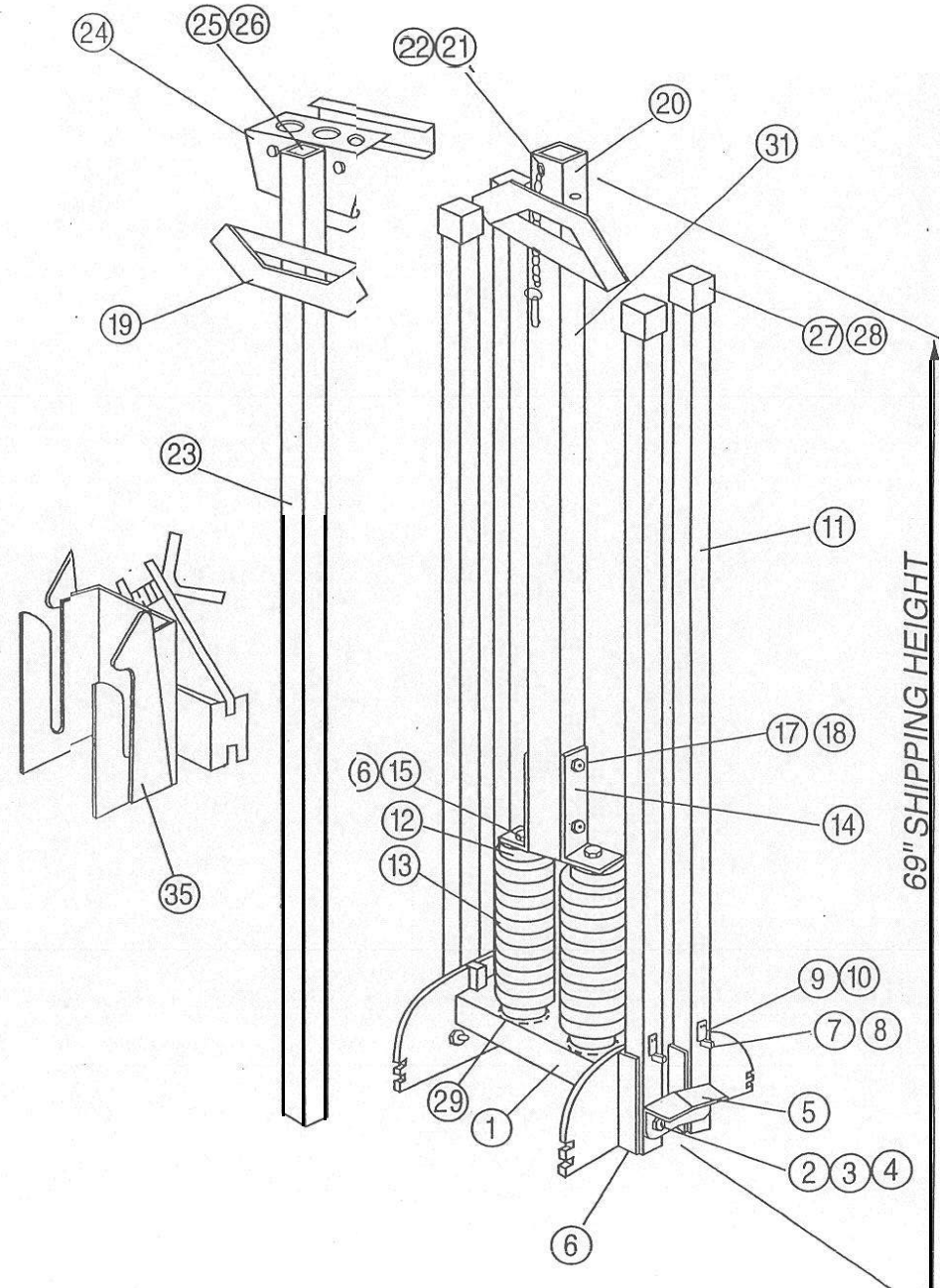



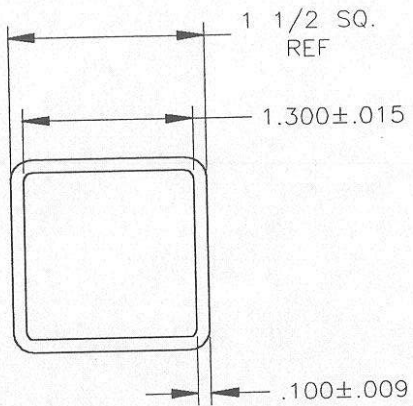

OUTER MAST

MATERIAL: 6061-T6 ALUM SQ. TUBING

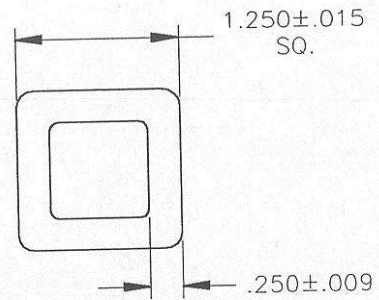

INNER MAST

MATERIAL: PVC SQ. TUBING

- NOTES:
- MIN CLEARANCE = .020  
MAX CLEARANCE = .080

Revision	Description	Approved	Date
-	NEW PART		11/9/99

TOLERANCES UNLESS OTHERWISE SPECIFIED  
 DECIMALS ANGLES  
 .XX = ±.03 ±1/2°  
 .XXX = ±.005  
 FRACTIONS  
 +1/32 -0

<i>TrafFix Devices, Inc.</i>			
Title TELESCOPING MAST, BIG BUSTER			
Directory	CAD File No. 10028	Drawing No. 10028	Rev --
Scale: FULL		Size: B	Sheet 1 of 1





48

1 1/4" x 3/16" x 62" LONG  
FIBERGLASS  
PULLTRUSION

1 1/4" x 1/4" x 62" LONG  
FIBERGLASS PULLTRUSION

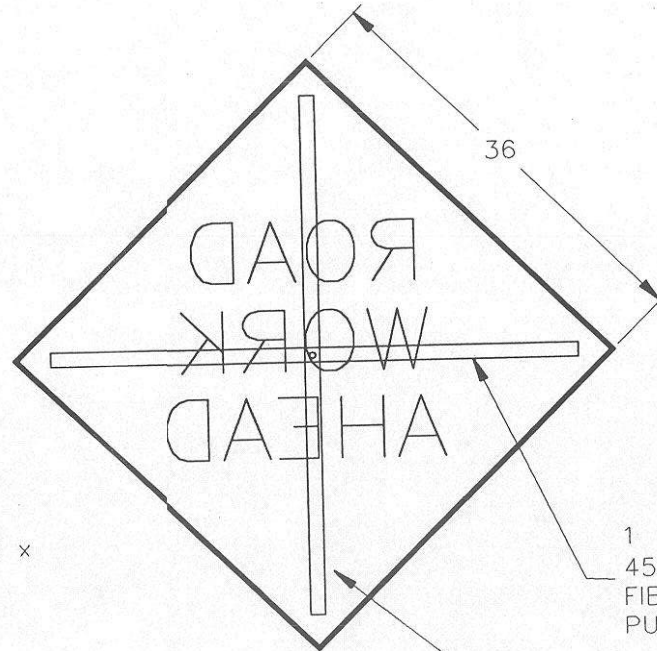

36

1 1/4" x 3/16" x 45" LONG  
FIBERGLASS  
PULLTRUSION

1 1/4" x 1/4" x 45" LONG  
FIBERGLASS PULLTRUSION

NOTES:

Revision	New part	Revision Description	Approved	Date

TOLERANCES UNLESS  
 OTHERWISE SPECIFIED  
 DECIMALS ANGLES  
 .XX - .03 .1°  
 .XXX - .005 .1°  
 FRACTIONS  
 +1/32 -0

**TrafFix Devices, Inc.**

Title: DUAL SPRING FOLDING LEG SIGN STAND  
BIG BUSTER

Directory: CAD File No. 10027 Drawing No. 10027 Rev. -

Scale: 1/4 Size: D Sheet 1 of 1

# TraFFix® ECONO BUSTER™

ITEM #	PART #	DESCRIPTION	QTY. PER ASSY..
1	80301	BASE PLATES	1
1A	80301B	HEX. BLT	2
2&18	24302	HEX LOCK NUT	6
3	24303	SPACER WASHER	8
4	24304	HEX BOLT	4
5	24305	TIE BRACKET	2
6	24306	CHANNEL BRACKET	4
7	24307	STEP LEVER	4
8	24308	EXTENSION SPRING	4
9	24309	COVER PLATE	4
10	24310	ROUND HEAD SCREW	8
11	24311	LEG	4
12	24319	LOCK WASHER	2
13	24320	OUTER MAST	1
14	24322	INSERTED PLATE SPRING	1
15	24323	INNER MAST	1
16	24324	FLAG HOLDER ASSY	1
16A	24324A	FLAG HOLDER	1
16B	24324B	CLAMP	1
16C	24324C	CARRIAGE BOLT	2
16D	24324D	COMPRESSION SPRING	2
16E	24324E	5/16 BUTTERFLY NUT	2
17	24325-A	ROUND HEAD SCREW	2
	24325-B	LOCK NUT	2
18	24326	BLACK CAP	4
19	80321	SIGN SIDE DECAL & LABEL	1
20	24321	RIGID SIGN BRACKET	2
21	24000-BRU	ROLL-UP SIGN BRACKET	1

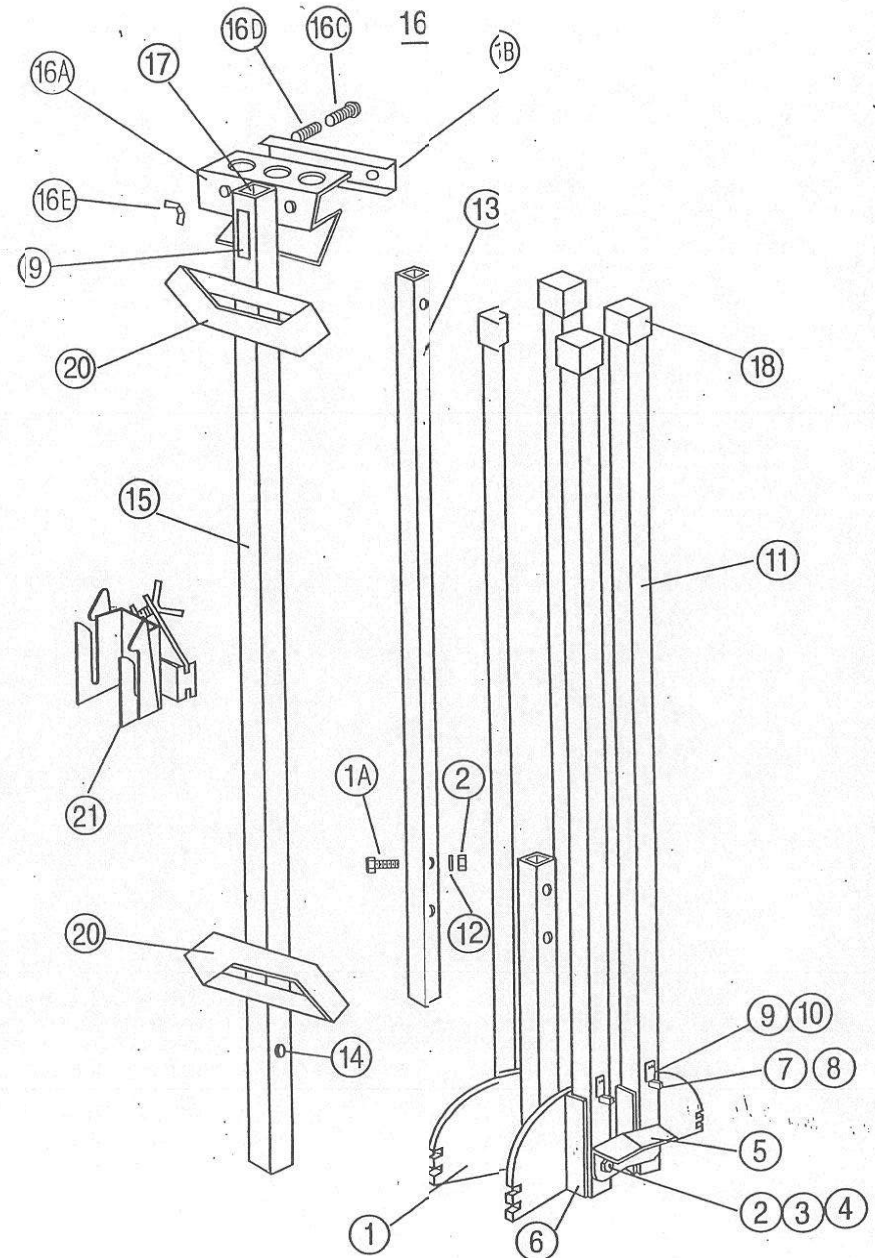

# TraFFix® LITTLE BUSHER™

ITEM #	PART #	ITEM DESCRIPTION	QT ASS
1	24301	Base Plate	1
2 & 18	24302	Hex. Lock Nut	6
3	24303	Spacer Washer	8
4 & 17	24304	Hex. Bolt	6
5	24305	Tie Bracket	2
6	24306	Channel Bracket	4
7	24307	Step Lever	4
8	24308	Extension Spring	4
9	24309	Cover Plate	4
10	24310	Round Head Screw	8
11	24311	Leg Including 24326 (Excluding 24307,24308, 24309, 24310)	4
12	24312	Insert Plug	4
13	24313	Spring	2
14	24314	Spring Bracket	2
15	24315	Hex. Bolt	4
16	24316	Lock Washer	4
19	24319	Lock Washer	2
20	24320	Outer Mast	1
21	24321	Rigid Sign Bracket	2
22	24322	Inserted Plate Spring	1
23	24323	Inner Mast (Excluding 24322, 24324 & 24325)	1
24	24324	Flag Holder Assembly	1
		Flag Holder Assy. Includes The Following	
24A	24324A	Flag Holder	1
24B	24324B	Flag Holder Clamp	1
24C	24324C	Carriage Bolt	1
24D	24324D	Compression Spring	2
24E	24324E	Butterfly Nut	2
25	24325-A	Round Head Screw	2
	24325-B	Lock Nut	2
26	24326	Black Cap	1
30	24000-BRU	Spring Loaded Roll-up Sign Bracket (optional)	1
31	24031	Sign Side Decal & Label	1
32	24329	Stiffener Washer	2

